



## Electric chain hoist with suspension hook model CPS

### Capacity 125 - 500 kg

The model CPS is the smallest and lightest model within the range of Yale electric chain hoists. Reliability and compact design make it ideal for numerous applications in the construction industry, service companies and many industrial areas for moving small and medium loads.

### Features

- Classification: 1 Am/M4 resp. 1 Bm/M3 at 230 V, 1-phase, 50 Hz. On request, the classification can be modified by derating the capacity and duty cycle.
- The standard version comes with direct control.
- Two year warranty (excluding wear parts).
- Thermal overload protection as standard.
- Duty cycle 30 % ED resp. 25 % ED at 230 V, 1-phase, 50 Hz.
- Safe hold of the load even in case of electric failure due to electromagnetic spring pressure brake.
- Standard operating voltage: Euro-voltage 400 V, 3-phase, 50 Hz resp. 125 kg also as 230 V, 1-phase, 50 Hz version.
- Motor protected to IP 54, against ingress of dust and splashing.
- Push-button pendant control, IP 65 against ingress of dust and water jets from all directions.
- The overload protection (slip clutch) avoids overloading and extends the lifetime of the hoist.
- Robust aluminium housing, powder coated.
- Extremely low headroom for use in applications with limited room.
- The standard case hardened and zinc-plated link chain is matched perfectly to the load chain to guarantee smooth and precise chain motion. All requirements of national and international standards and regulations are fulfilled.
- The 10-pocket load sheave ensures smooth running of the chain and minimizes chain wear.
- Drop forged suspension and load hooks are made from non-aging, high tensile steel and fitted with robust safety latches.

## INFO

---

Festooned cable systems please see pages 140-141.

### Options

- Stainless steel load chain (no reduction of working load limit).
- Robust chain container.
- Low voltage control 48 V
- Manual and electric trolleys.
- Connection to festooned cable systems.

## Technical data model CPS

Model	EAN-No. 4025092*	Capacity in kg/ number of chain falls	Standard lifting height m	Chain dimensions d x p mm	Classification FEM/ISO	Lifting speed m/min	Hoist motor kW	Weight kg	Operating voltage
CPS 1-4	*076654	125/1	3	4x12.2	1Bm/M3	4	0.10	11.5	230V/1 Ph/50 Hz
CPS 1-10	*076661	125/1	3	4x12.2	1Am/M4	10	0.25	11.5	400V/3 Ph/50 Hz
CPS 2-6	*076678	250/1	3	4x12.2	1Am/M4	6	0.28	11.5	400V/3 Ph/50 Hz
CPS 5-3	*076685	500/2	3	4x12.2	1Am/M4	3	0.28	12.5	400V/3 Ph/50 Hz

## Dimensions model CPS

Model	CPS 1-4	CPS 1-10	CPS 2-6	CPS 5-3
A, mm	276	276	276	303
B, mm	98	98	98	146
C, mm	159	159	159	159
D, mm	75	75	75	60
E, mm	76	76	76	91
F, mm	160	160	160	160
G, mm	227	227	227	227
H, mm	103	103	103	103
I, mm	52	52	52	52
J <sup>1</sup> , mm	1905	1905	1905	1905
X, mm	25	25	25	25
Y, mm	14	14	14	14
Z, mm	21	21	21	21

<sup>1</sup> Dimensions at standard lift (3 m).

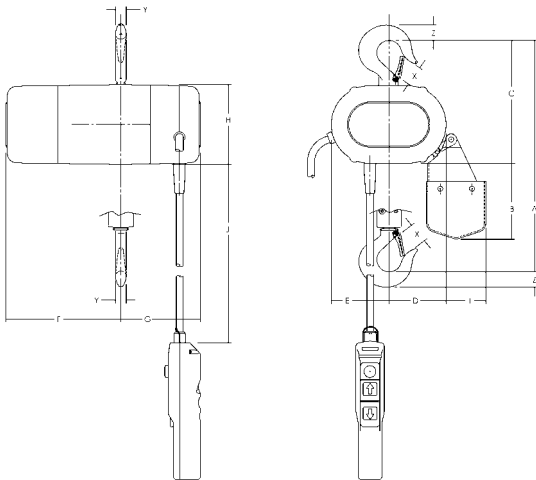

Smallest and lightest electric chain hoist for a great number of applications.

## INFO

Yale hoists and trolleys are not designed for passenger elevation applications and must not be used for this purpose.



*High speed units up to 18 m/min available*

## Options

- Stainless steel load chain (no reduction of working load limit).
- Suspension hook
- Flexible chain container.
- Other operating voltages
- Counter for operating hours and number of starts.
- Radio remote control
- Control for synchronized operation of several hoists.
- Manual and electric trolleys.
- Connection to festooned cable systems
- Suspension for light crane systems.

## Electric chain hoist with suspension lug or with integrated trolley model CPV

Capacity 250 - 2000 kg

The electric chain hoist model CPV combines modern design and technical innovation. A robust construction makes the series a versatile tool for professional applications. The integrated limit switch for the highest and lowest hook position considerably extends the working life span of the slip clutch, motor and gearbox.

## Features

- Classification 1 Am/M4. For 1-phase hoists: 1 Bm/M3. As required (with appropriate changes to lifting capacity resp. duty cycle) the model CPV can also be re-classified up to 3m/M6.
- Main contactor as standard, for increased safety.
- Increased operating safety through 42V control voltage (low voltage control), push-button pendant control, IP 65.
- 2 year warranty (excluding wear parts) and a lifetime lubricated gearbox.
- Duty cycle 50% ED for single speed.
- Electromagnetic spring pressure brake holds the load safely even in the event of power failure.
- Standard operating voltage: Euro-voltage 400V, 3-phase, 50 Hz.
- Motor protected to IP 55 (acc. to VDE 0530), against ingress of dust and water jets.
- The externally adjustable slip clutch is designed to guarantee a permanent connection between the load and the brake.
- The standard, oil bath lubricated and case hardened gearbox has a helical gearing for particularly smooth running and enhanced lifetime. Greased gearbox by CPV/F 2-8.
- Suspension lug for compact dimensions and easy integration in closed-eye constructions.
- Steel chain guide, model CPV/F 2-8 comes with chain guides made of POM.

## INFO

Also available as 230V, 1-phase, 50Hz (25% ED) version. Optionally available with electric trolley.

1-phase units are single speed only!  
High speed units (18m/min) are not available as 230V, 1-phase!

Festooned cable systems please see pages 140-141.

## Technical data model CPV/CPVF

Model	EAN-No. 4025092* 4053981**	Capacity in kg/ number of chain falls	Chain dimensions d x p  mm	Classification  FEM/ISO	Lifting speed <sup>4</sup> main lift	Lifting speed fine lift	Hoist motor  kW	Motor rating  ED %	Weight <sup>1</sup> suspension lug  kg	Weight <sup>1</sup> push trolley <sup>2</sup>  kg	Weight <sup>1</sup> electric trolley <sup>3</sup>  kg
					m/min	m/min					
CPV 2-8	-	250/1	4 x 12.2	1Am/M4	8	-	0.37	50	on request	on request	on request
CPVF 2-8	**874067	250/1	4 x 12.2	1Am/M4	8	2	0.37/0.09	33/17	19	28	33
CPVF 2-18	*925341	250/1	5 x 15.1	1Am/M4	18	4.5	0.75/0.18	33/17	27	42	50
CPV 5-4	-	500/2	4 x 12.2	1Am/M4	4	-	0.37	50	on request	on request	on request
CPVF 5-4	**874074	500/2	4 x 12.2	1Am/M4	4	1	0.37/0.09	33/17	19	28	33
CPV 5-8	*173766	500/1	5 x 15.1	1Am/M4	8	-	0.75	50	26	41	49
CPVF 5-8	*173803	500/1	5 x 15.1	1Am/M4	8	2	0.75/0.18	33/17	27	42	50
CPVF 5-18	*303729	500/1	7.1 x 20.5	1Am/M4	18	4.5	1.5/0.37	33/17	59	78	85
CPV 10-4	*174473	1000/2	5 x 15.1	1Am/M4	4	-	0.75	50	28	43	51
CPVF10-4	*174725	1000/2	5 x 15.1	1Am/M4	4	1	0.75/0.18	33/17	29	44	52
CPV 10-8	*173797	1000/1	7.1 x 20.5	1Am/M4	8	-	1.5	50	58	77	84
CPVF10-8	*173780	1000/1	7.1 x 20.5	1Am/M4	8	2	1.5/0.37	33/17	59	78	85
CPV 20-4	*174480	2000/2	7.1 x 20.5	1Am/M4	4	-	1.5	50	63	82	89
CPVF 20-4	*174459	2000/2	7.1 x 20.5	1Am/M4	4	1	1.5/0.37	33/17	64	83	90

<sup>1</sup> Weight at standard lift (3 m). Other lifting heights on request.

<sup>2</sup> For trolleys type A and B: Additional weight for geared trolley (VTG): 2.5 kg

<sup>3</sup> For electric trolley (VTE) with 2 speeds +2.0 kg

<sup>4</sup> Lifting speed CPV 10-8 at 230 V, 1-phase, 50 Hz = 4 m/min

Lifting speed CPV 20-4 at 230 V, 1-phase, 50 Hz = 2 m/min

## INFO

Yale hoists and trolleys are not designed for passenger elevation applications and must not be used for this purpose.



Increased operating safety through 42 V control voltage



Externally adjustable slip clutch



Integrated limit switch



Depicted suspension hook and chain container optionally available.

Option: radio remote control

## Technical data trolleys

Suitable for model	Capacity  kg	Size	Beam flange width b mm	Beam flange thickness t max. mm	Curve radius min.  m	Electric trolley travel speed m/min at 50 Hz	Electric trolley motor kW at 50 Hz
CPV/CPVF 2-8 up to CPVF 5-4	500	A	58 - 180	12	0.9	11 or 18	0.09
CPV/CPVF 2-8 up to CPVF 5-4	500	B	180 - 300	19	0.9	18 or 18	0.09
CPV 5-8 up to CPVF 10-4	1000	A	58 - 180	19	0.9	18 or 18/4.5	0.18 or 0.18/0.06
CPV 5-8 up to CPVF 10-4	1000	B	180 - 300	19	0.9	18 or 18/4.5	0.18 or 0.18/0.06
CPV 10-8 up to CPVF 20-4	2000	A	58 - 180	19	1.15	18 or 18/4.5	0.18 or 0.18/0.06
CPV 10-8 up to CPVF 20-4	2000	B	180 - 300	19	1.15	18 or 18/4.5	0.18 or 0.18/0.06

## Dimensions model CPV/CPVF

Model	CPV 2-8/ CPVF 2-8	CPV 5-4/ CPVF 5-4	CPVF 2-18 CPV/CPVF 5-8	CPV/CPVF 10-4	CPVF 5-18 CPV/CPVF 10-8	CPV/CPVF 20-4
A, mm	357/327	357/327	357	430	431	528
A1, mm	196/163	196/163	196	196	234	234
A2 (Size I), mm	476/343	476/343	476	476	564	564
A2 (Size II), mm	526/413	526/413	526	526	644	644
A2 (Size III), mm	606/483	606/483	606	606	734	734
A2 (Size IV), mm	798/553	798/553	798	798	934	934
B, mm	22/23	22/23	22	29	29	37
B1, mm	15/12	15/12	15	15	20	20
C, mm	29/30	29/30	29	35	35	40
C1, mm	38/30	38/30	38	38	45	45
C2, mm	105	105	105	105	154	154
D, mm	15/16	15/16	15	21	21	26
D1, mm	15/12	15/12	15	15	15	15
E, mm	277/205	277/205	277	277	326	326
G, mm	120/102	120/102	120	144	140	173
G1 (Size I), mm	142/124	142/124	142	166	175	208
G1 (Size II), mm	162/124	162/124	162	186	175	208
G1 (Size III), mm	162/124	162/124	162	186	175	208
G1 (Size IV), mm	162/124	162/124	162	186	175	208
H, mm	157/99	157/99	157	133	186	154
H2, mm	158/92	158/92	158	158	186	186
K, mm	208/215	208/215	208	208	285	285
M (Size I), mm	162/157	162/157	162	162	209	209
M (Size II), mm	197/157	197/157	197	197	209	209
M (Size III), mm	197/157	197/157	197	197	209	209
M (Size IV), mm	197/157	197/157	197	197	209	209
N <sup>1</sup> , mm	219/159	219/159	219	219	274	274

<sup>1</sup>for 230V, 1-phase, 50 Hz: +35 mm

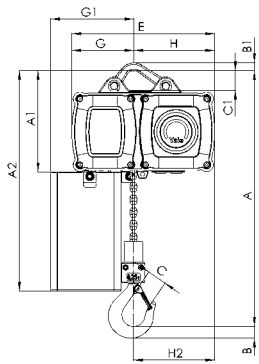

Model CPV/CPVF  
with suspension lug, 250 - 1000 kg, single fall

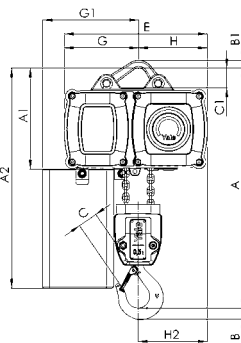
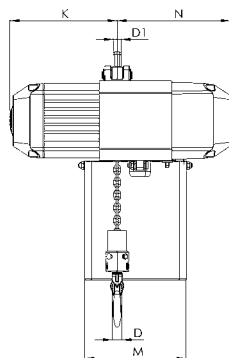

Model CPV/CPVF  
with suspension lug, 500 - 2000 kg, double fall

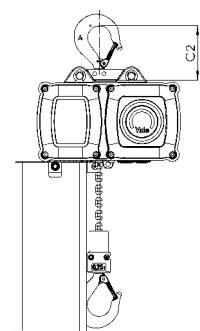
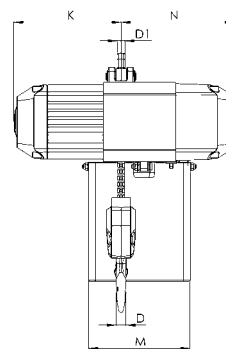

Model CPV/CPVF  
with suspension hook,  
250 - 2000 kg

Dimensions model CPV/CPVF

Model	CPV 2-8/ CPVF 2-8	CPV 5-4/ CPVF 5-4	CPVF 2-18 CPV/CPVF 5-8	CPV/CPVF 10-4	CPVF 5-18 CPV/CPVF 10-8	CPV/CPVF 20-4
A3, mm	228/199	228/199	228	228	263	263
A4 (Size I), mm	508/379	508/379	508	508	593	593
A4 (Size II), mm	558/449	558/449	558	558	673	673
A4 (Size III), mm	638/519	638/519	638	638	768	768
A4 (Size IV), mm	830/589	830/589	830	830	968	968
A5, mm	389/365	389/365	389	462	460	558
b, mm	A = 58 - 180 B = 180 - 300	A = 58 - 180 B = 180 - 300	A = 58 - 180 B = 180 - 300	A = 58 - 180 B = 180 - 300	A = 58 - 180 B = 180 - 300	A = 58 - 180 B = 180 - 300
H1, mm	24/25	24/25	24	24	23	23
H3, mm	129/113	129/113	129	129	129	129
H4 (VTG), mm	95	95	95	95	95	95
H4 (VTE), mm	142	142	142	142	142	142
I (Push trolley), mm	72	72	72	72	96	96
I (Geared trolley), mm	77/76	77/76	77	77	98	98
L (VTP/VTG), mm	310	310	310	310	360	360
L1, mm	130	130	130	130	150	150
L2 (CPV), mm	255	255	255	255	255	255
L2 (CPVF), mm	222	222	263	263	263	263
L3, mm	155/135	155/135	155	155	180	180
L4, mm	161/131	161/131	173	161	203	203
O, mm	60	60	60	60	80	80
P, mm	200/171	200/171	180	180	180	180
P1, mm	246/236	246/236	246	246	246	246
S, mm	b + 50	b + 50	b + 50	b + 50	b + 54	b + 54
T, mm	94	94	94	94	94	94
tmax., mm	19/12	19/12	19	19	19	19

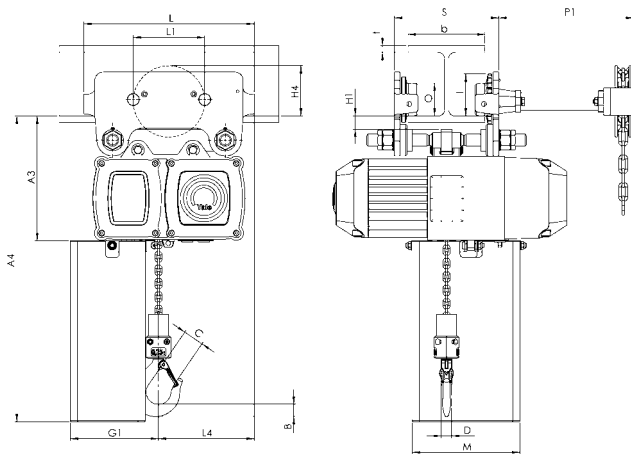

Model CPV/CPVF with integrated manual push or geared trolley

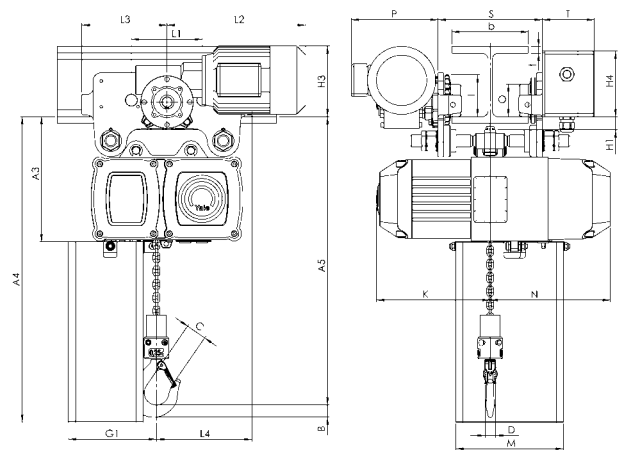

Model CPV/CPVF with integrated electric trolley



### Electric chain hoist with suspension hook or with integrated trolley model CPE

Capacity 1600 - 10000 kg

The CPE series is a range of high quality products for professional applications. They are highly efficient and engineered for a long working life. The hoists are composed of three main component parts which makes service easy and inexpensive.

#### Features

- Classification 1 Am/M4, except models CPE(F) 20-8, CPE(F) 30-5 and CPE(F) 40-4, with classification 1 Bm/M3. On request, the classification can be modified by derating the capacity and duty cycle.
  - Direct control or 42V low voltage control.
  - 2 year warranty (excluding wear parts) as well as a lifetime lubricated gear box.
  - Motor fitted with a bimetallic thermal protection (useable in connection with low voltage control).
  - Duty cycle 40% at one operating speed.
  - The heavy duty squirrel cage motor has an adjustable spring pressure brake that holds the load secure even in the event of a power failure.
  - Standard operating voltage:  
Euro-voltage 400V, 3-phase, 50 Hz.
  - Motor protected to IP 54, insulation class F.
  - Encapsulated pendant control protected to IP 65, against ingress of dust and water jets.
  - The 5-pocket load chain sheave, manufactured from wear resistant case hardening steel, is matched perfectly to the load chain to guarantee smooth and precise chain motion.
  - The standard, oil bath lubricated planetary gearbox is particularly smooth running.
  - Drop forged suspension and load hooks are made from non-aging, high tensile steel and fitted with robust safety latches.
  - The standard case hardened and zinc-plated link chain is matched perfectly to the load chain to guarantee smooth and precise chain motion.
- All requirements of national and international standards and regulations are fulfilled.

#### Options

- Stainless steel load chain.
- Suspension hook rotated 90°.
- Flexible chain container.
- Other operating voltages.
- Limit switches for highest and lowest hook positions (in combination with low voltage control).
- Motor with stainless steel brake.
- Radio remote control.
- Control for synchronized operation of several hoists.
- Manual and electric trolleys.
- Integrated low headroom trolley.
- Festooned cable system.

## Twin hoist model CPE 100-2

### Capacity 10000 kg

The model CPE 100-2 consists of two CPE 50-2 units.

They are connected by a framework.

Hook suspension, geared or electric trolleys are available.

Integrated limit switches for highest and lowest hook positions are standard.

42 V low voltage control as standard.

### Options

- Stainless steel load chain.
- Flexible chain container.
- Other operating voltages.
- Motor with stainless steel brake.
- Radio remote control.
- Festooned cable system.



## INFO

The units are certified by the employer's liability insurance association (Berufsgenossenschaft) and fulfil the requirements of the machinery directive 2006/42/EG.

Festooned cable systems please see pages 140-141.



**5-pocket load chain sheave** machined for smooth, precise chain motion.



**Universal connection** to suspension hook, trolley or steel structures.



**Double fall bottom block** for capacities between 3200 up to 5000 kg.



**Hoist connected directly to trolley** with electric drive. Manual pull and geared trolleys also available.



**Option:** Flexible chain container made from wear resistant textile fabric.





*Electric chain hoist  
with  
low headroom  
integrated trolley*

Compact planetary gearbox

Zinc-plated Yale load chain

Push-button pendant control, IP 65

## INFO

The low headroom hoist CPE LH is available on request in capacities up to 5t with the resp. standard speeds.

Yale hoists and trolleys are not designed for passenger elevation applications and must not be used for this purpose.

## Technical data model CPE/CPEF

Model	EAN-No. 4025092*	Capacity in kg/ number of chain falls	Chain dimensions d x p mm	Classification  FEM/ISO	Lifting speed main lift m/min	Lifting speed fine lift m/min	Hoist motor  kW	Motor rating  ED %
CPE 16-8	*073240	1600/1	11x31	1Am/M4	8	-	2.3	40
CPEF 16-8	*073257	1600/1	11x31	1Am/M4	8	2	2.3/0.58	40/20
CPE 20-8	*073264	2000/1	11x31	1Bm/M3	8	-	2.8	25
CPEF 20-8	*073271	2000/1	11x31	1Bm/M3	8	2	2.8/0.7	25/15
CPE 25-5	*073288	2500/1	11x31	1Am/M4	5	-	2.3	40
CPEF 25-5	*073295	2500/1	11x31	1Am/M4	5	1.25	2.3/0.58	40/20
CPE 30-5	*073301	3000/1	11x31	1Bm/M3	5	-	2.8	25
CPEF 30-5	*073318	3000/1	11x31	1Bm/M3	5	1.25	2.8/0.7	25/15
CPE 32-4	*073325	3200/2	11x31	1Am/M4	4	-	2.3	40
CPEF 32-4	*073332	3200/2	11x31	1Am/M4	4	1	2.3/0.58	40/20
CPE 40-4	*073349	4000/2	11x31	1Bm/M3	4	-	2.8	25
CPEF 40-4	*073356	4000/2	11x31	1Bm/M3	4	1	2.8/0.7	25/15
CPE 50-2	*073363	5000/2	11x31	1Am/M4	2.5	-	2.3	40
CPEF 50-2	*073370	5000/2	11x31	1Am/M4	2.5	0.6	2.3/0.58	40/20
CPE 75-1,6	*079907	7500/3	11x31	1Am/M4	1.6	-	2.8	40
CPEF 75-1,6	*079914	7500/3	11x31	1Am/M4	1.6	0.4	2.8/0.58	40/20
CPE 100-2	*060585	10000/4	11x31	1Am/M4	2.5	-	2x2.3	40
CPEF 100-2	*060592	10000/4	11x31	1Am/M4	2.5	0.6	2x2.3/0.58	40/20

Model	Weight <sup>1</sup> suspension hook kg	Weight <sup>1</sup> push trolley kg	Weight <sup>1</sup> geared trolley kg	Weight <sup>1</sup> electric trolley <sup>2</sup> kg
CPE 16-8	88	150	154	164
CPEF 16-8	93	155	159	169
CPE 20-8	88	150	154	164
CPEF 20-8	93	155	159	169
CPE 25-5	88	150	154	164
CPEF 25-5	93	155	159	169
CPE 30-5	88	150	154	164
CPEF 30-5	93	155	159	169
CPE 32-4	107	169	173	182
CPEF 32-4	112	174	178	187
CPE 40-4	107	169	173	182
CPEF 40-4	112	174	178	187
CPE 50-2	107	169	173	182
CPEF 50-2	112	174	178	187
CPE 75-1,6	220	320	320	340
CPEF 75-1,6	226	326	326	346
CPE 100-2 <sup>3</sup>	282	-	385	406
CPEF 100-2 <sup>3</sup>	287	-	390	411

<sup>1</sup>Weight at standard lift (3 m). Other lifting heights on request.

<sup>2</sup>Additional weight for 2 speed version 2.0 kg

<sup>3</sup>Limit switches for highest and lowest hook positions – 42V low voltage control



## INFO

Festooned cable systems please see pages 140-141.

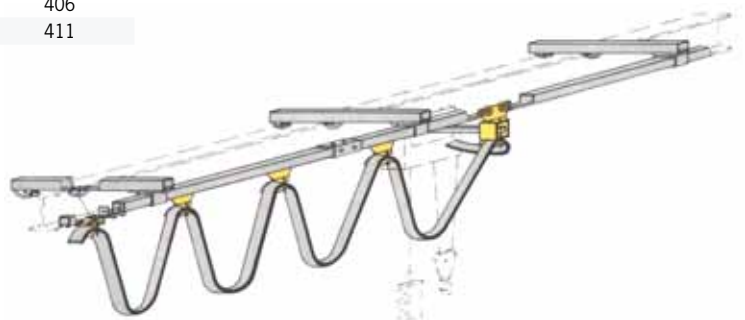

## Technical data trolleys

Capacity kg	Size	Beam flange width b mm	Beam flange thickness t max. mm	Curve radius min. m	Electric trolley travel speed m/min at 50 Hz	Electric trolley motor kW at 50 Hz
1600 - 5000	A	98 - 180	27	2.0	11 or 11/2.8	0.37 or 0.3/0.09
1600 - 5000	B	180 - 300	27	1.8	11 or 11/2.8	0.37 or 0.3/0.09
7500 - 10000	B	125 - 310	40	1.8	5 or 5/1.25	0.55 or 0.55/0.12

## Dimensions model CPE/CPEF

Model	CPE/CPEF 16-8	CPE/CPEF 20-8	CPE/CPEF 25-5	CPE/CPEF 30-5	CPE/CPEF 32-4	CPE/CPEF 40-4	CPE/CPEF 50-2	CPE/CPEF 75-1,6	CPE/CPEF 100-2
A, mm	516	516	516	516	681	681	681	950	1068
A1, mm	286	286	286	286	428	428	428	479	651
A2 (13m), mm	430	430	430	430	430	430	430	-	-
A2 (21m), mm	530	530	530	530	530	530	530	530	555
B, mm	35	35	35	35	45	45	45	60	60
C, mm	37	37	37	37	46	46	46	52	52
D, mm	24	24	24	24	30	30	30	40/45	40/45
E, mm	24	24	24	24	24	24	24	-	-
F1, mm	160	160	160	160	160	160	160	160	160
F2, mm	178	178	178	178	178	178	178	178	178
G, mm	220	220	220	220	220	220	220	220	-
G1, mm	180	180	180	180	140	140	140	268	315
G2 (13m), mm	257	257	257	257	218	218	218	-	-
G2 (21m), mm	277	277	277	277	238	238	238	345	408
H1, mm	110	110	110	110	110	110	110	110	135
H2, mm	135	135	135	135	135	135	135	307	256
K1, mm	100	100	100	100	100	100	100	92	92
K2, mm	51	51	51	51	51	51	51	62	62
M, mm	50	50	50	50	10	10	10	138	-
N, mm	84	84	84	84	124	124	124	136	390
Q1, mm	280	280	280	280	280	280	280	280	280
Q2 (CPE), mm	362	362	362	362	362	362	362	362	362
Q2 (CPEF), mm	417	417	417	417	417	417	417	417	417

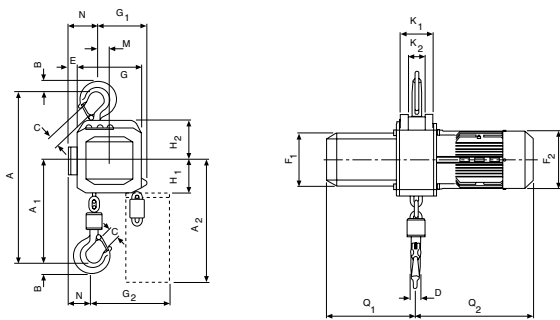

Model CPE/CPEF with suspension hook, 1600 - 3000 kg, single fall

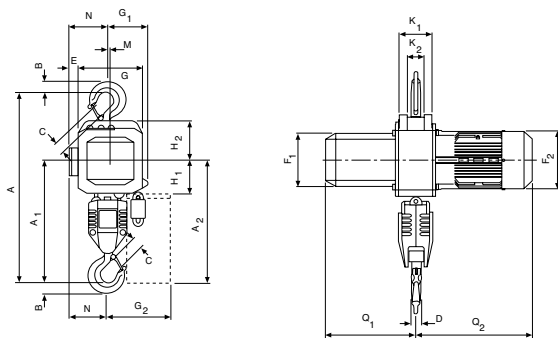

Model CPE/CPEF with suspension hook, 3200 - 5000 kg, double fall

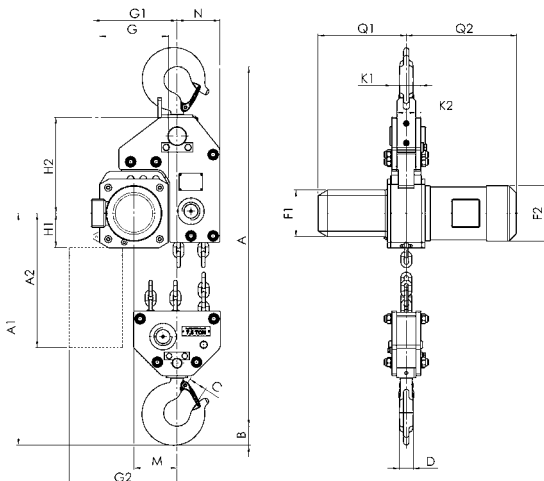

Model CPE/CPEF 75-1,6 with suspension hook, 7500 kg

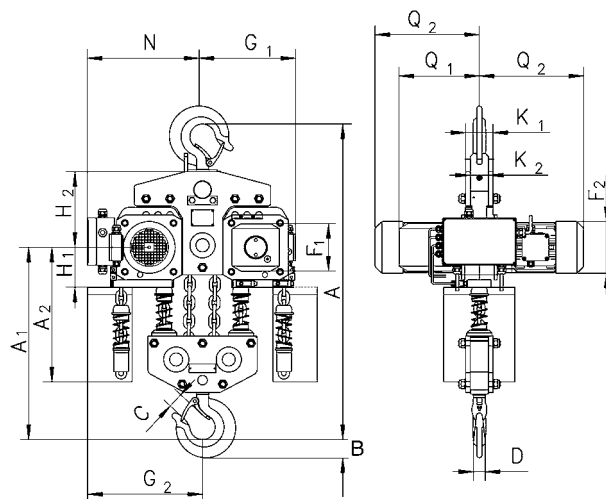

Model CPE/CPEF 100-2 with suspension hook, 10000 kg

Dimensions model CPE/CPEF

Model	CPE/CPEF 16-8	CPE/CPEF 20-8	CPE/CPEF 25-5	CPE/CPEF 30-5	CPE/CPEF 32-4	CPE/CPEF 40-4	CPE/CPEF 50-2	CPE/CPEF 75-1,6	CPE/CPEF 100-2
A3, mm	121	121	121	121	121	121	121	-	110
A4, mm	465	465	465	465	615	615	615	855	965
A5, mm	298	298	298	298	298	298	298	477	450
A6, mm	178	178	178	178	178	178	178	-	170
b, mm	A = 98 - 180/ B = 180 - 300	A = 98 - 180/ B = 180 - 300	A = 98 - 180/ B = 180 - 300	A = 98 - 180/ B = 180 - 300	A = 98 - 180/ B = 180 - 300	A = 98 - 180/ B = 180 - 300	A = 98 - 180/ B = 180 - 300	125 - 310	125 - 310
F, mm	150	150	150	150	150	150	150	113	113
l, mm	142.5	142.5	142.5	142.5	142.5	142.5	142.5	170	170
L1, mm	209	209	209	209	209	209	209	200	200
L2, mm	262.5	262.5	262.5	262.5	262.5	262.5	262.5	215	215
L3 (VTE), mm	292	292	292	292	292	292	292	-	335
L3 (VTEF), mm	296	296	296	296	296	296	296	-	335
L4, mm	213	213	213	213	253	253	253	215	390
L5, mm	312	312	312	312	272	272	272	215	215
L6 (VTE), mm	342	342	342	342	342	342	342	-	-
L6 (VTEF), mm	346	346	346	346	306	306	306	-	-
O, mm	125	125	125	125	125	125	125	150	150
P (VTE), mm	197	197	197	197	197	197	197	-	273
P (VTEF), mm	205	205	205	205	205	205	205	-	280
P1, mm	229	229	229	229	229	229	229	-	110
S, mm	b + 70	b + 70	b + 70	b + 70	b + 70	b + 70	b + 70	b + 98	b + 98
T, mm	94	94	94	94	94	94	94	-	94
tmax., mm	27	27	27	27	27	27	27	40	40

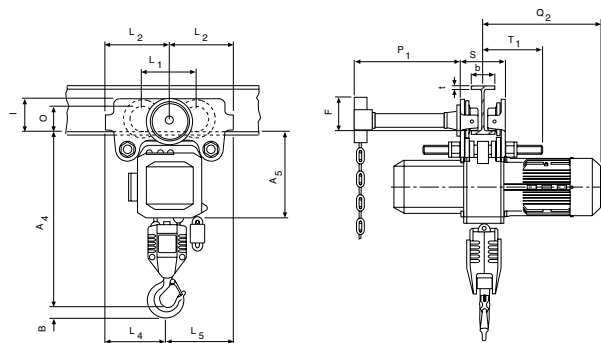

Model CPE/CPEF with integrated manual push or geared trolley

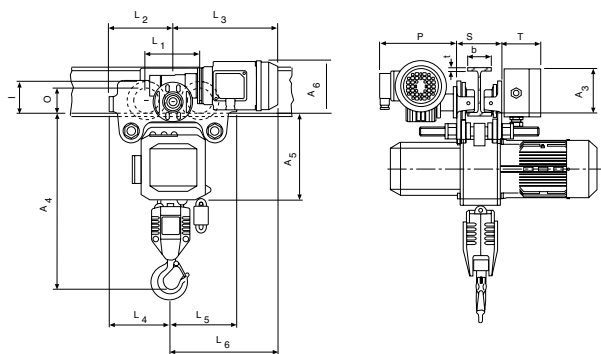

Model CPE/CPEF with integrated electric trolley

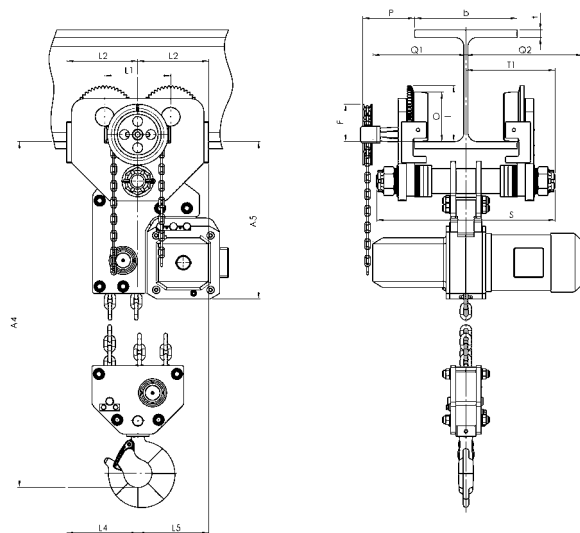

Model CPE/CPEF with integrated geared or electric trolley, 7500 kg

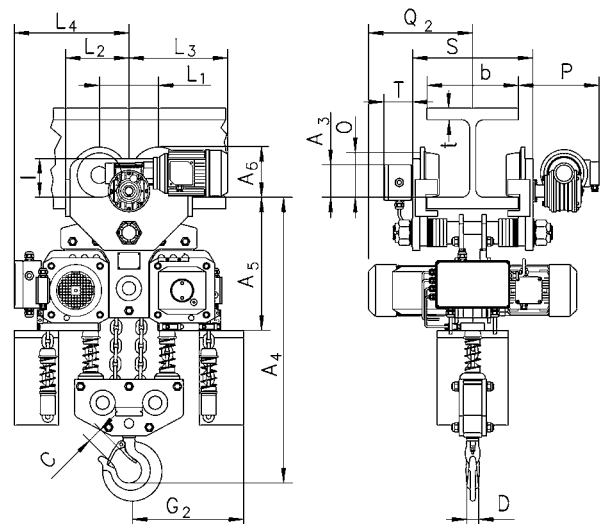

Model CPE/CPEF with integrated electric trolley, 10000 kg



Available in explosion proof version (please see page 442).

## Pneumatic chain hoist model CPA

Capacity 125 - 980 kg

Pneumatic chain hoists are characterized by high durability in a great number of industrial applications. The robust but light weight housing allows an easy transport.

### Features

- Working pressures 5-7 bar.
- Rotating piston motor with 100% duty rating and an unlimited number of starts for continuous operation.
- Integrated limit switches for highest and lowest hook position as standard.
- Self-adjusting automatic disc brake.
- Extremely sensitive control with emergency-stop for a precise positioning of the load.
- Air release for brake as standard for models CPA 2-31, CPA 5-17 and CPA 10-9

### Options

- All models available with push or geared trolley.
- Models CPA 2-31, CPA 5-17 and CPA 10-9 also available with chain control.
- Maintenance unit for main air supply pipe (pressure regulator, manometer, lubricator and support).
- Chain container

### Applications

Automobile and aircraft industries, shipyards, on ships and docks. Foundries, on-/offshore, paint factories and paint shops, refineries, oil depots, galvanizing. Printing, textile and food industries, pulp, paper and cement mills. Glass and ceramic industries, wood working industries, chemical industries, heat treatment and power plants etc.

## INFO

To ensure faultless operation the compressed air supply must be filtered and oiled!

Also suitable for operation with nitrogen.

Yale hoists and trolleys are not designed for passenger elevation applications and must not be used for this purpose.

Technical data model CPA

Model	EAN-No. 4025092*	Capacity in kg/ number of chain falls	Chain dimensions d x p mm	Classification FEM/ISO	Lifting speed with rated load <sup>1</sup> m/min	Lifting speed without load <sup>1</sup> m/min	Lowering speed with rated load <sup>1</sup> m/min	Air consumption with rated load <sup>1</sup> m <sup>3</sup> /min	Hoist motor kW	Weight at standard lift (3 m) kg
CPA 1-13	*911795	125/1	4x12.2	1Am/M4	13.1	17.1	11.3	0.9	0.4	15.4
CPA 2-10	*911788	250/1	4x12.2	1Am/M4	9.8	17.1	13.7	0.9	0.4	15.4
CPA 2-31	*911801	250/1	6.3x19.5	1Bm/M3	31.0	52.0	36.0	2.1	1.33	21.8
CPA 5-5	*911818	500/2	4x12.2	1Am/M4	4.6	7.9	6.7	0.9	0.4	17.2
CPA 5-17	*911825	500/1	6.3x19.5	1Bm/M3	16.8	32.3	29.6	2.1	1.33	21.8
CPA 10-9	*911832	980/2	6.3x19.5	1Bm/M3	8.5	16.2	14.9	2.1	1.33	27.7

<sup>1</sup> Values for 6.3 bar (flow pressure) and 2 m control drop. Speeds will be reduced in case of longer control length.

Model CPA 1-13, CPA 2-10 and CPA 5-5 hose length max. 12 m, air supply 3/8" NPT

Model CPA 2-31, CPA 5-17 and CPA 10-9 hose length max. 20 m, air supply 1/2" NPT.

Dimensions model CPA

Model	CPA 1-13	CPA 2-10	CPA 2-31	CPA 5-5	CPA 5-17	CPA 10-9
A, mm	292	292	457	324	457	457
A1, mm	410	410	483	410	483	508
B, mm	21	21	25	14	25	27
C, mm	20	20	24	24	24	28
D, mm	16	16	26	14	26	28
F1, mm	90	90	130	90	130	130
F2, mm	120	120	180	120	180	180
K, mm	103	103	146	103	146	165
L, mm	57	57	102	57	102	83
M, mm	120	120	114	120	114	135
N, mm	50	50	54	50	54	25
Q1, mm	142	142	162	142	162	162
Q2, mm	183	183	181	183	181	181

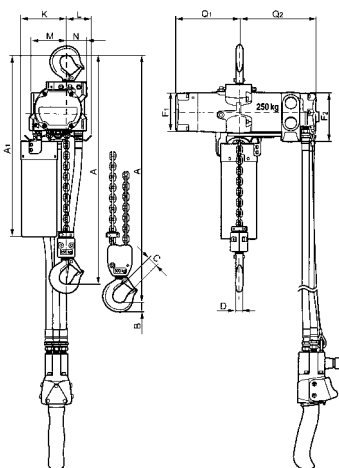

Model CPA 1-13/ 2-10/ 5-5

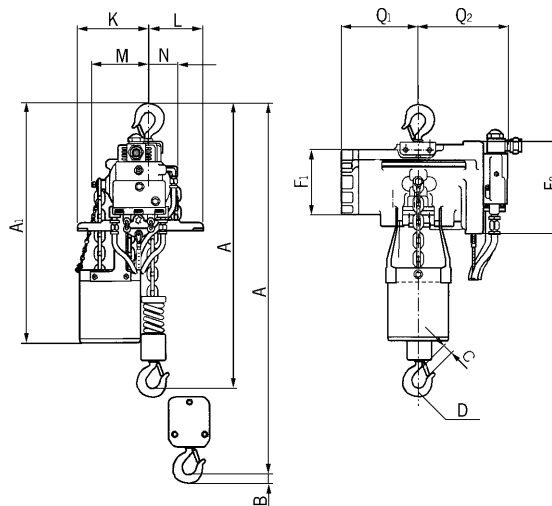

Model CPA 2-31 / 5-17 / 10-9



## INFO

To ensure faultless operation the compressed air supply must be filtered and oiled!

Also suitable for operation with nitrogen.

Yale hoists and trolleys are not designed for passenger elevation applications and must not be used for this purpose.

Other capacities on request.

## Pneumatic chain hoist with suspension hook or with integrated trolley model CPA

Capacity 2000 - 10000 kg

The conception is in accordance with the design of the model CPE.

With 100% duty rating and an unlimited number of starts the model CPA is suitable for heavy duty applications. It is insusceptible to contamination, humidity and aggressive mediums from the outside. The hoists are composed of three main components which makes service easy and inexpensive.

### Features

- Working pressures 4-6 bar.
- Robust rotating piston motor has an adjustable spring pressure brake that holds the load secure even in the event of an air failure.
- The standard, oil bath lubricated planetary gearbox is particularly smooth running and enables a low overall height.
- High starting torque due to switching valves in the motor body.
- Low noise emission due to large dimension silencer.
- Sensitive control by means of 2 resp. 4 button pendant control with emergency-stop.
- Up to 3000 kg only one chain fall, leading to a low overall height.
- The 5-pocket load chain sheave, manufactured from wear resistant case hardening steel, is matched perfectly to the load chain to guarantee smooth and precise chain motion.
- Drop forged suspension and load hooks are made from non-aging, high tensile steel and fitted with robust safety latches.
- The standard case hardened and zinc-plated link chain is matched perfectly to the load chain to guarantee smooth and precise chain motion.

All requirements of national and international standards and regulations are fulfilled.

### Options

- Manual and pneumatic trolleys.
- Rope control
- Stainless steel load chain.



Available in explosion proof version (see page 444).

## Technical data model CPA

Model	EAN-No. 4025092*	Capacity in kg/ number of chain falls	Chain dimensions d x p mm	Classification  FEM/ISO	Lifting speed with rated load <sup>1</sup> m/min	Lifting speed without load <sup>1</sup> m/min	Lowering speed with rated load <sup>1</sup> m/min	Hoist motor  kW
CPA 20-8	*073868	2000/1	11x31	1Bm/M3	7.4	9.9	11.0	2.6
CPA 30-6	*073875	3000/1	11x31	1Bm/M3	6.0	9.9	13.0	3.2
CPA 40-4	*073882	4000/2	11x31	1Bm/M3	3.7	5.0	5.5	2.6
CPA 50-3	*073899	5000/2	11x31	1Am/M4	3.4	5.0	6.0	3.0
CPA 60-3	*073905	6000/2	11x31	1Am/M4	3.0	5.0	6.5	3.2
CPA 75-2	*056915	7500/3	11x31	1Am/M4	2.0	3.3	4.3	3.2
CPA 100-3	*075701	10000/4	11x31	1Am/M4	3.4	5.0	6.0	2x3.0

<sup>1</sup> Values for 6 bar (flow pressure), air consumption with rated load 4.7 m<sup>3</sup>/min. CPA 100-3: 9.4 m<sup>3</sup>/min.

Model	EAN-No. 4025092*	Weight <sup>2</sup> suspension hook kg	Weight <sup>2</sup> push trolley kg	Weight <sup>2</sup> geared trolley kg	Weight <sup>2</sup> pneumatic trolley kg
CPA 20-8	*073868	121	184	188	199
CPA 30-6	*073875	121	184	188	199
CPA 40-4	*073882	140	202	206	218
CPA 50-3	*073899	140	202	206	218
CPA 60-3	*073905	140	202	206	218
CPA 75-2	*056915	-	-	-	-
CPA 100-3	*075701	-	-	-	-

<sup>2</sup> Weight at standard lift (3 m). Other lifting heights on request.



Available in explosion proof version (please see page 444).



Application with pneumatic trolley



## Technical data trolleys

Capacity  kg	Size	Beam flange width b mm	Beam flange thickness t max. mm	Curve radius min. m	Pneumatic trolley travel speed m/min	Pneumatic trolley motor kW
2000 - 6000	A	98 - 180	27	2.0	18	0.55
2000 - 6000	B	180 - 300	27	1.8	18	0.55
7500 - 10000	B	125 - 310	40	1.8	-	-

Values for 6 bar (flow pressure), air consumption with rated load 0.75 m<sup>3</sup>/min.



## Dimensions model CPA

Model	CPA 20-8	CPA 30-6	CPA 40-4	CPA 50-3	CPA 60-3	CPA 75-2	CPA 100-3
A, mm	516	516	681	681	681	950	1068
A1, mm	286	286	428	428	428	479	651
B, mm	35	35	45	45	47	60	60
C, mm	37	37	46	46	42	52	52
D, mm	24	24	30	30	30	40/45	40/45
F1, mm	160	160	160	160	160	160	160
F2, mm	165	165	165	165	165	165	165
G, mm	220	220	220	220	220	220	581
G1, mm	180	180	140	140	140	268	311
G2 (13 m), mm	258	258	218	218	218	-	-
G2 (21 m), mm	278	278	238	238	238	345	408
H1, mm	110	110	110	110	110	110	110
H2, mm	135	135	135	135	135	307	256
H3, mm	115	115	115	115	115	115	115
K1, mm	100	100	100	100	100	92	92
K2, mm	51	51	51	51	51	62	62
M, mm	50	50	9.6	9.6	9.6	139	181
N, mm	60	60	100	100	100	136	291
Q1, mm	272	272	272	272	272	272	272
Q2, mm	325	325	325	325	325	325	325

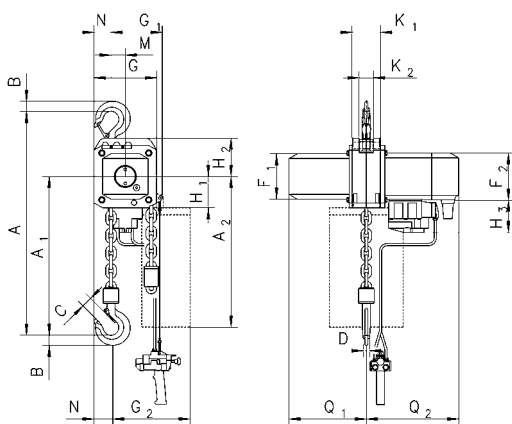

Model CPA with suspension hook, 2000 - 3000 kg, single fall

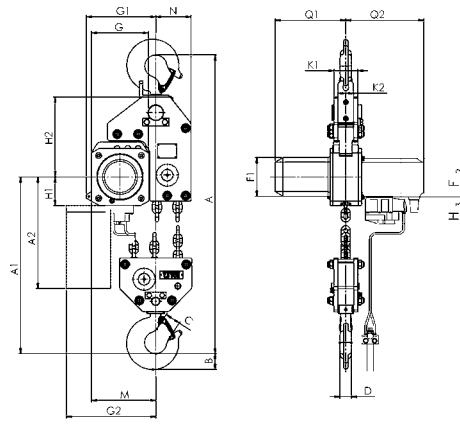

Model CPA with suspension hook, 7500 kg, three fall

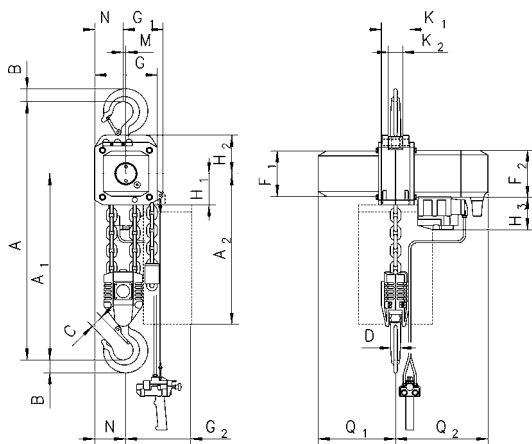

Model CPA with suspension hook, 4000 - 5000 kg, double fall

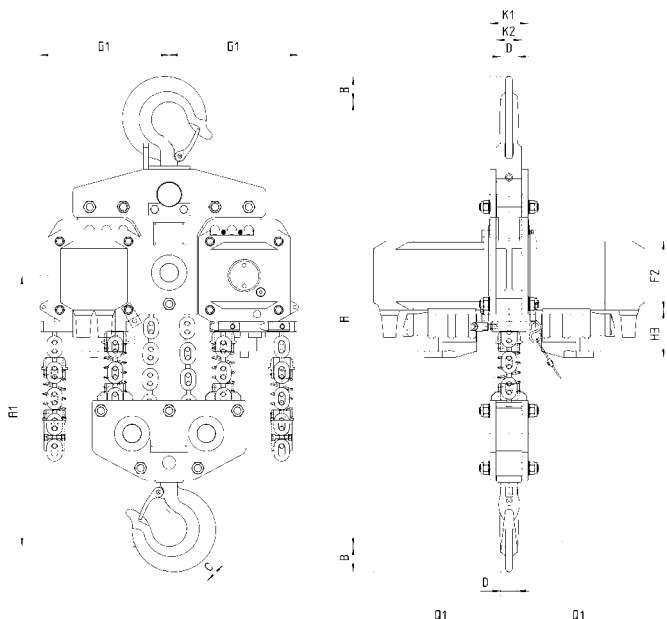

Model CPA with suspension hook, 10000 kg, four fall

Dimensions model CPA

Model	CPA 20-8	CPA 30-6	CPA 40-4	CPA 50-3	CPA 60-3	CPA 75-2	CPA 100-3
A2 (13 m), mm	430	430	430	430	430	-	-
A2 (21 m), mm	530	530	530	530	530	530	530
A4, mm	465	465	615	615	615	855	965
A5, mm	298	298	298	298	298	477	425
A6, mm	190	190	190	190	190	182	182
b, mm	A = 98 - 180/ B = 180 - 300	A = 98 - 180/ B = 180 - 300	A = 98 - 180/ B = 180 - 300	A = 98 - 180/ B = 180 - 300	A = 98 - 180/ B = 180 - 300	125 - 310	125 - 310
F, mm	150	150	150	150	150	113	113
l, mm	142.5	142.5	142.5	142.5	142.5	130	130
L1, mm	209	209	209	209	209	200	200
L2, mm	262.5	262.5	262.5	262.5	262.5	215	215
L3, mm	265	265	265	265	265	265	265
L4, mm	213	213	253	253	253	291	291
L5, mm	312	312	272	272	272	-	-
L6, mm	315	315	275	275	275	-	-
O, mm	125	125	125	125	125	150	150
P, mm	208	208	208	208	208	208	208
P1, mm	284	284	284	284	284	284	284
S, mm	b + 70	b + 70	b + 70	b + 70	b + 70	b + 98	b + 98
t, mm	27	27	27	27	27	40	40
T1 size A	182	182	182	182	182	-	-
T1 size B	242	242	242	242	242	270	270

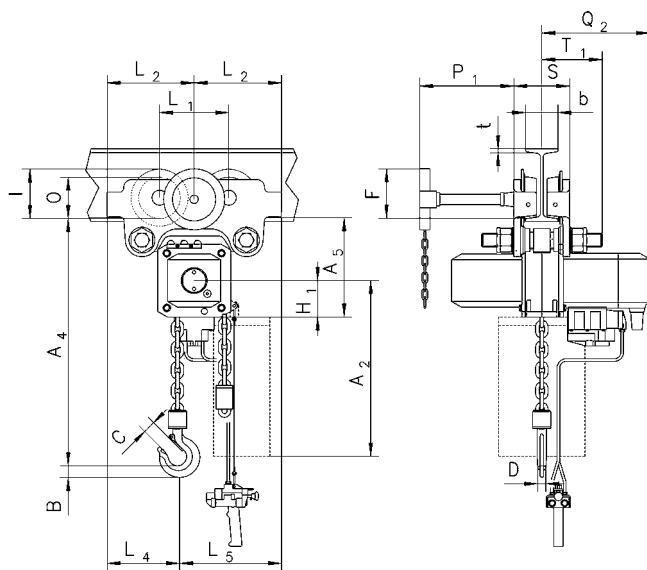

Model CPA with integrated manual push or geared trolley

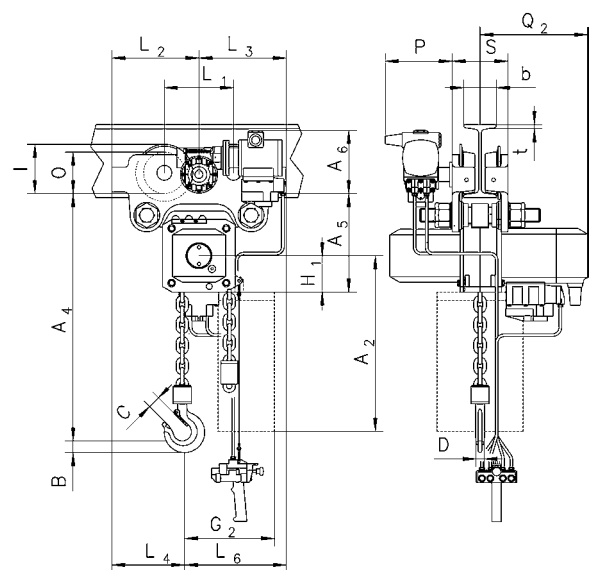

Model CPA with integrated pneumatic trolley

## Yale link chains, zinc-plated

for	EAN-No. 4025092*	Capacity  kg	Number of chain falls	Chain dimensions d x p mm	Chain stop
Model D85	*050920	750	1	6 x 18.5	•
	*050937	1500	1	9 x 27	•
	*050951	3000	1	11 x 31	•
	*050951	6000	2	11 x 31	•
	*050951	10000	3	11 x 31	•
Model D95	*051002	1500	1	6.2 x 18.5	•
	*051422	3000	1	9 x 27.2	•
Model AL	*051323	750	1	6.3 x 19.1	•
	*051323	1000	1	6.3 x 19.1	•
	*051347	1500	1	7.1 x 21.2	•
	*051378	3000	1	10 x 30.2	•
Model PT	*051415	800	1	5.6 x 17.1	•
	*051347	1600	1	7.1 x 21.2	•
	*051422	3200	1	9 x 27.2	•
	*051422	6300	2	9 x 27.2	•
Model UNOplus	*053846	750	1	6 x 18	•
	*053860	1500	1	8 x 24	•
	*053884	3000	1	10 x 30	•
	*053884	6000	2	10 x 30	•
Model Yalehandy	*051316	250	1	4 x 12	–
	*051316	500	1	4 x 12	–
Model Yalelift 360	*075244	500	1	5 x 15	–
	*053846	1000	1	6 x 18	•
	*053860	2000	1	8 x 24	•
	*053884	3000	1	10 x 30	•
	*053884	5000	2	10 x 30	•
	*077002	10000	3	10 x 30	•
	*077002	20000	6	10 x 30	•
Model VSIII	*051316	250	1	4 x 12	–
	*075244	500	1	5 x 15	–
	*053846	1000	1	6 x 18	•
	*053860	1500	1	8 x 24	•
	*053846	2000	2	6 x 18	•
	*053860	2000	1	8 x 24	•
	*053860	3000	2	8 x 24	•
	*053884	3000	1	10 x 30	•
	*053884	5000	2	10 x 30	•
Model CPS	*076074	125 - 250	1	4 x 12.2	–
	*076074	500	2	4 x 12.2	–
Model CPV	*076074	250	1	4 x 12.2	–
	*076074	500	2	4 x 12.2	–
	*081030	500	1	5 x 15.1	–
	*081030	1000	2	5 x 15.1	–
	*081047	1000	1	7.1 x 20.5	•
	*081047	2000	2	7.1 x 20.5	•
	Model CPA	*076074	125 - 250	1	4 x 12.2
*076074		500	2	4 x 12.2	–
*890649		250 - 500	1	6.3 x 19.5	•
*890649		980	2	6.3 x 19.5	•
Model CPE/CPA	*056489	1600 - 3000	1	11 x 31	•
	*056489	3200 - 6000	2	11 x 31	•
	*056489	7500	3	11 x 31	•
	*056489	10000	4	11 x 31	•

